

T1360

MECHANICAL DRIVE
WHEEL TRENCHER

TRENGOR

by ASTEC



BREAKTHROUGH SOLUTIONS

T1360 Wheel Trencher

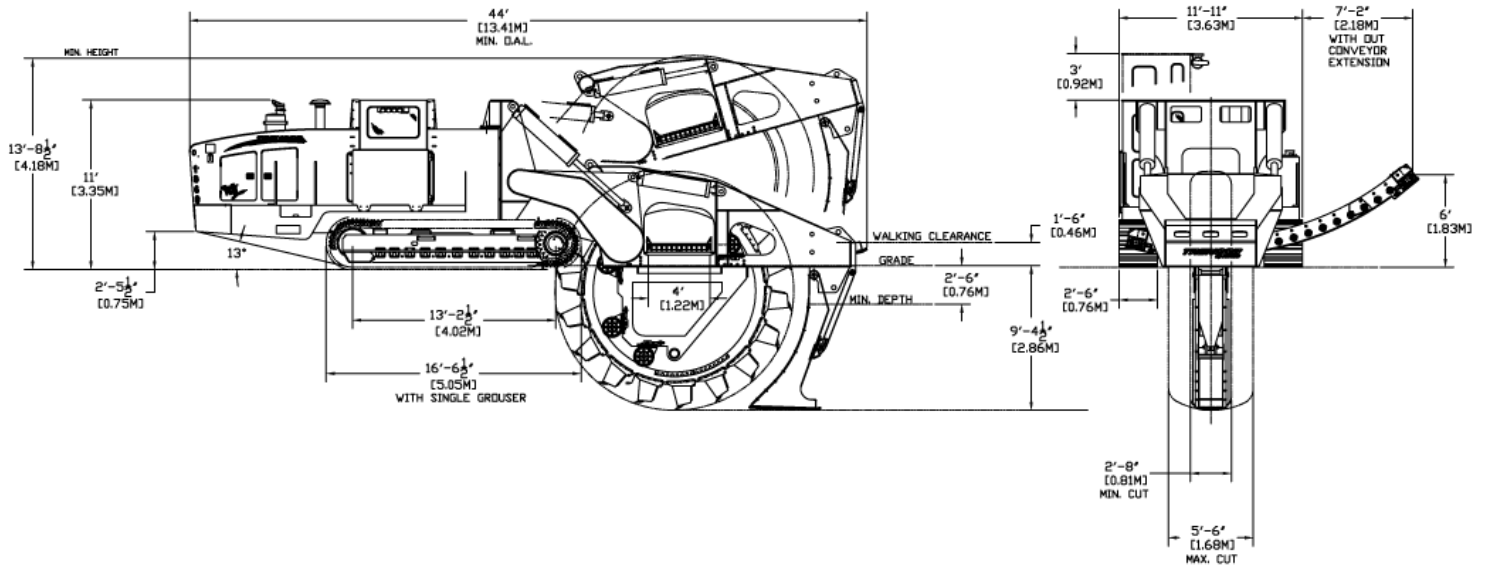

ENGINE

- Caterpillar C13 Acert turbocharged diesel, Tier 3 Stage IIIA emissions
- 440 hp (328 Kw) @ 2100 RPM
- 1483 ft-lbs (2011 N-m) @ 1400 RPM
- Fuel rate consumption: 22.8 Gal (86.3L)/hour at full horsepower
- 24-volt DC electrical system
- Cooling system — up to 125 F ambient (52 C)
- Heavy-duty 2-stage air cleaner

FUEL CAPACITY

Dual tanks 250 gal. (946 L)
 Operation 11 hours at full horsepower

HYDRAULIC SYSTEM

Single bolt-on tank 200 gal. (757 L)
 Crawler drive Closed loop piston pumps
 Conveyor drive Closed loop piston pumps
 Accessory Open loop

TRACK DRIVE

Infinitely variable hydrostatic/mechanical
 Speed 2 mph (3.2 kph)
 Track control Independent proportional electric over hydraulic
 Load control Microcontroller with bypass
 Crawlers Cat D-7 components
 Grouser 30-inch (762 mm) wide, low-profile single grousers

OPERATOR STATION

Fully enclosed, air conditioned, heated, and pressurized cab
 Elevation 36 in. (915 mm)

DIGGING ASSEMBLY

Heavy-duty mechanical chain drive. Power shift transmission with four trenching speeds and reverse.
 Trench depth 9 ft. (2750 mm)
 Trench width 32 to 66 in (813 to 1676 mm)

CONVEYOR

Arc type conveyor with hydraulic shift
 Belt width 48 in. (1220 mm)
 Belt speed 0 to 900 fpm (275 mpm)

ADDITIONAL STANDARD ITEMS

- Breakaway crumb shoe
- Noise abatement equipment
- Work lights (2 fore/2 aft)

OPTIONAL EQUIPMENT

- Automatic laser control for grade
- Automatic laser control for steering
- Cold weather package

APPROXIMATE WEIGHT AND DIMENSIONS

Weight 135,000 - 150,000 lbs. (61,363 - 68,180 Kg)
 Width 11 ft., 11 in. (3630 mm)
 Height without wheel 11 ft. (3353 mm)
 Height with wheel 13 ft., 9 in. (4178 mm)
 Length with wheel 44 ft (13,411 mm)

IMPORTANT: Astec Underground reserves the right to change these specifications without notice and without incurring any obligation relating to such change. This literature has been published for world-wide circulation. Availability of some models and equipment builds vary according to the country in which the equipment is used. The illustrations and text may include optional equipment and accessories and may not include all standard equipment. Your Astec dealer/distributor will be able to give you details of the products and their specifications available in your area.

NOTE: All specifications are stated in accordance with SAE Standards or Recommended Practices, where applicable.

© 2007 ASTEC UNDERGROUND. All Rights Reserved. TREN_1360wheel_3_07

ASTEC UNDERGROUND an Astec Industries Company

9600 CORPORATE PARK DR • LOUDON, TN 37774 USA • 800.527.6020 FAX 865.458.8575 • astecunderground.com

