

RT160 *plus*
TOOL CARRIER

ASTEC



BREAKTHROUGH SOLUTIONS



RT160^{plus} TOOL CARRIER

The Astec line of walk-behind and ride-on utility trenchers, vibratory plows and horizontal directional drills, along with related parts and accessories, offers users a broad choice of underground construction solutions.

The forerunners of the Astec machines were developed by Charles Davis in 1959. Recognized as an industry leader, Davis trenchers were renowned for their innovative designs and rugged reliability. The line was purchased by Case in 1969, and the machines carried the Case-Davis label until the mid 1970s when the Davis name was dropped. Case nurtured the line until 2002 when it was sold to Astec Underground and the machines received the Astec brand.

Astec Underground continues to enhance the line's reputation for performance and durability. Mainstay models like the Maxi-Sneaker and TF300B still have a respected place in the Astec lineup. Innovative walk-behind trenchers like the RT130 and RT160 are quickly joining them. These newly engineered units pay homage to the Astec heritage while confidently demonstrating the company's vision for the future.

Astec products are manufactured at the company's 360,000 square-foot facility in Loudon, Tenn., alongside the company's Trenchor line of rock trenchers, surface miners, road miners, and related equipment. Astec has owned the Trenchor brand since 1988. The combination of these respected names provides customers with unsurpassed choices to meet their trenching needs.

Astec products are sold and supported through a worldwide network of 47 dealers that operate more than 94 locations. These dealers sell new and used Astec machines, and provide the parts and service to help customers minimize downtime and get needed repair parts.

Visit www.astecunderground.com to learn about the full line of Astec Underground products or to contact the company for more information.

THE RIGHT TOOL FOR ANY JOB

SELECT A TRENCHER, LANDSCAPE RAKE, BLADE, SNOW BLOWER, OR BROOM (NOT SHOWN) TO ADD MAXIMUM VERSATILITY.



TRENCHER OPTIONS

EQUIP THE RT160 PLUS WALK-BEHIND TRENCHER TO MEET YOUR NEEDS WITH OPTIONAL ITEMS LIKE A CRUMB SHOE, EARTHPRO GROUND ENGAGING SYSTEMS DIGGING CHAIN, AND YOUR CHOICE OF A 24-, 36-, OR 48-IN (610-, 914, OR 1,219 MM) DIGGING BOOM.



YEAR ROUND ROI

THE RT160 PLUS TOOL CARRIER KEEPS WORKING YEAR ROUND FOR MAXIMUM ROI. LOOSEN A FEW SIMPLE BOLTS, REMOVE THE TRENCHER COMPONENTS, AND YOU'RE READY TO CHOOSE FROM 5 DIFFERENT ATTACHMENTS.



ERGONOMIC CONTROLS

USER-FRIENDLY, SINGLE JOYSTICK OPERATION WITH CREEP CONTROL MAKES THE RT160 PLUS EASY TO OPERATE.

DEPENDABLE HYDRAULICS

THE ATTACHMENT LIFT IS CONTROLLED BY A HYDRAULIC CYLINDER, AND THE HYDRAULIC DRIVE IS CAPABLE OF RUNNING ATTACHMENTS UP TO 13 GPM.



CHANGE TAKES SECONDS

THE QUICK-ATTACH FEATURE ENSURES IT TAKES ONLY SECONDS TO CHANGE TOOLS FOR THE TASK AT HAND.



BALANCED PERFORMANCE

THE TOOL CARRIER'S WEIGHT AND LOW CENTER OF GRAVITY PROVIDE EXCEPTIONAL BALANCE AND PERFORMANCE FOR A WIDE RANGE OF USEFUL TOOLS.



BREAKTHROUGH SOLUTIONS

RT160^{plus} TOOL CARRIER

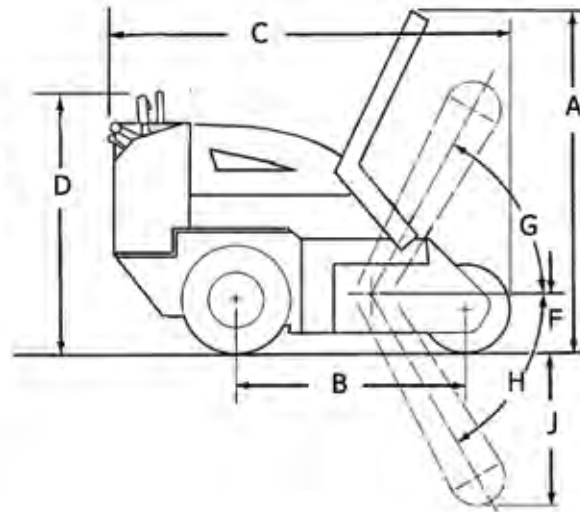
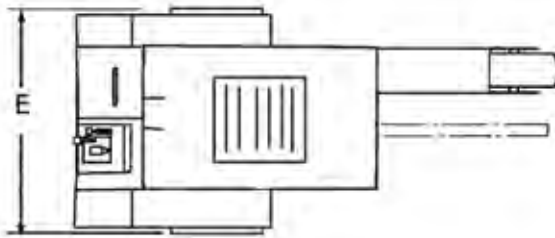

BASIC SPECS

- Honda GX670 twin-cylinder, 4-stroke gasoline engine
- Engine oil cooler
- Air-cooled with remote air cleaner
- 12-volt electric start, throttle, choke, fuel shutoff, oil alert
- Gross horsepower: 24 hp (18 Kw) @ 3,600 RPM
- Fuel tank capacity 5 gal (18.93 L)
- Filter type Single, in-line
- Ground drive Hydrostatic
- Tires 23 x10.5x12 rear
..... 13x5x12 front
- Trencher drive Hydraulic motor directly connected to trencher head shaft
- Steering (hydraulic) 23° turning angle
- Hydraulic oil cooler
- Automatic parking brake Spring-applied with tow capability
- Heavy-duty boom with 7-in (178 mm) tail roller with sealed bearing
- Heavy-duty boom pivots
- Boom is equipped with a grease fitting for easy chain adjustment and quick service.

TRANSMISSION

- Hydrostatic pump to independent motor at each wheel.
- Closed loop system with flow divider provides positive flow to both wheels, eliminating need for differential lock.
- Variable speeds (forward/reverse).
- Single joystick control for F-N-R and creep control

GROUND TRAVEL SPEEDS

Maximum speed forward 1.7 mph (2.74 kph)
Maximum speed reverse 1 mph (1.6 kph)

BASIC MACHINE DIMENSIONS

A. Transport height (48-in boom fully raised)	62 in (1,575 mm)
B. Wheelbase	36.5 in (927 mm)
C. Overall length	74 in (1,879 mm)
D. Height to top of controls	47 in (1,194 mm)
E. Overall width with standard tires	44 in (1,117.6 mm)
F. Height boom pivot to ground	11.5 in (292 mm)
G. Boom travel, up	45 degrees
H. Boom travel, down	60 degrees
J. Trench maximum depth	48 in (1,219 mm)
Overall width	
w/ Standard tires (23x10.5x12)	44 in (1,118 mm)
w/Optional tires (23x6x12)	36 in (914 mm)
w/ Dual tires (23x6x12)	50 in (1,270 mm)
Dig depth	up to 24, 30, 36, 42, or 48 in
.....	(610, 762, 914, 1,067 or 1,219 mm)
Trench widths	4 to 8 in (102 to 203 mm)

APPROXIMATE WEIGHT

Total 1,530 lbs (698 kg)
NOTE: Weight includes 36-in (914 mm) boom with 6-in (152 mm) wide chain, without wheel weights.

OPTIONAL EQUIPMENT

- Hydra-Borer System
- Wheel Weights
- Snow Blower Attachment
- EarthPro Ground Engaging Systems Digging Chain
- Dual Wheels
- Broom Attachment
- Rake Attachment

IMPORTANT: Astec Underground reserves the right to change these specifications without notice and without incurring any obligation relating to such change. This literature has been published for world-wide circulation. Availability of some models and equipment builds vary according to the country in which the equipment is used. The illustrations and text may include optional equipment and accessories and may not include all standard equipment. Your Astec dealer/distributor will be able to give you details of the products and their specifications available in your area.

NOTE: All specifications are stated in accordance with SAE Standards or Recommended Practices, where applicable. © 2007 ASTEC UNDERGROUND. All Rights Reserved. ASTEC_RT160PLUS_2_07

ASTEC UNDERGROUND an Astec Industries Company

9600 CORPORATE PARK DR • LOUDON, TN 37774 USA • 800.527.6020 FAX 865.458.8575 • astecunderground.com

