

# RT160<sup>plus</sup> TOOL CARRIER

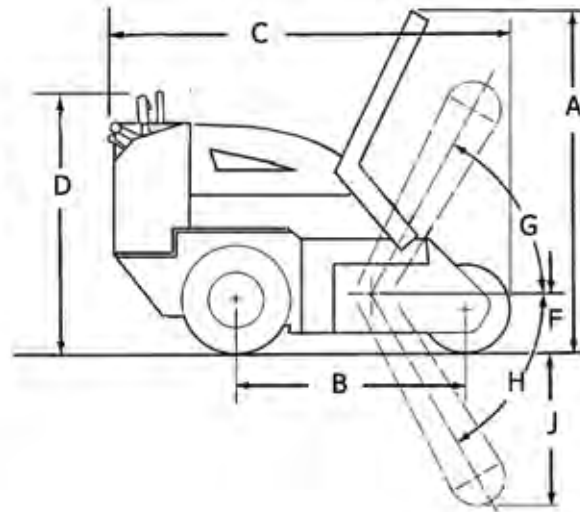
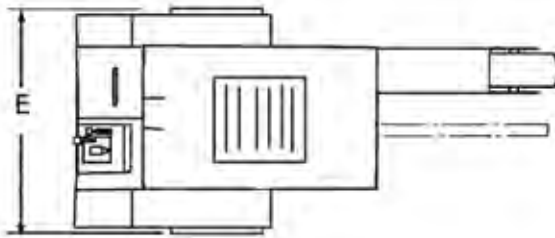

## BASIC SPECS

- Honda GX670 twin-cylinder, 4-stroke gasoline engine
- Engine oil cooler
- Air-cooled with remote air cleaner
- 12-volt electric start, throttle, choke, fuel shutoff, oil alert
- Gross horsepower: ..... 24 hp (18 Kw) @ 3,600 RPM
- Fuel tank capacity ..... 5 gal (18.93 L)
- Filter type ..... Single, in-line
- Ground drive ..... Hydrostatic
- Tires ..... 23 x10.5x12 rear  
..... 13x5x12 front
- Trencher drive ..... Hydraulic motor directly connected to trencher head shaft
- Steering (hydraulic) ..... 23° turning angle
- Hydraulic oil cooler
- Automatic parking brake ..... Spring-applied with tow capability
- Heavy-duty boom with 7-in (178 mm) tail roller with sealed bearing
- Heavy-duty boom pivots
- Boom is equipped with a grease fitting for easy chain adjustment and quick service.

## TRANSMISSION

- Hydrostatic pump to independent motor at each wheel.
- Closed loop system with flow divider provides positive flow to both wheels, eliminating need for differential lock.
- Variable speeds (forward/reverse).
- Single joystick control for F-N-R and creep control

## GROUND TRAVEL SPEEDS

Maximum speed forward ..... 1.7 mph (2.74 kph)  
Maximum speed reverse ..... 1 mph (1.6 kph)

## BASIC MACHINE DIMENSIONS

A. Transport height (48-in boom fully raised) .....	62 in (1,575 mm)
B. Wheelbase .....	36.5 in (927 mm)
C. Overall length .....	74 in (1,879 mm)
D. Height to top of controls .....	47 in (1,194 mm)
E. Overall width with standard tires .....	44 in (1,117.6 mm)
F. Height boom pivot to ground .....	11.5 in (292 mm)
G. Boom travel, up .....	45 degrees
H. Boom travel, down .....	60 degrees
J. Trench maximum depth .....	48 in (1,219 mm)
Overall width	
w/ Standard tires (23x10.5x12) .....	44 in (1,118 mm)
w/Optional tires (23x6x12) .....	36 in (914 mm)
w/ Dual tires (23x6x12) .....	50 in (1,270 mm)
Dig depth .....	up to 24, 30, 36, 42, or 48 in
.....	(610, 762, 914, 1,067 or 1,219 mm)
Trench widths .....	4 to 8 in (102 to 203 mm)

## APPROXIMATE WEIGHT

Total ..... 1,530 lbs (698 kg)  
NOTE: Weight includes 36-in (914 mm) boom with 6-in (152 mm) wide chain, without wheel weights.

## OPTIONAL EQUIPMENT

- Hydra-Borer System
- Wheel Weights
- Snow Blower Attachment
- EarthPro Ground Engaging Systems Digging Chain
- Dual Wheels
- Broom Attachment
- Rake Attachment

IMPORTANT: Astec Underground reserves the right to change these specifications without notice and without incurring any obligation relating to such change. This literature has been published for world-wide circulation. Availability of some models and equipment builds vary according to the country in which the equipment is used. The illustrations and text may include optional equipment and accessories and may not include all standard equipment. Your Astec dealer/distributor will be able to give you details of the products and their specifications available in your area.

NOTE: All specifications are stated in accordance with SAE Standards or Recommended Practices, where applicable. © 2007 ASTEC UNDERGROUND. All Rights Reserved. ASTEC\_RT160PLUS\_2\_07

**ASTEC UNDERGROUND** an Astec Industries Company

9600 CORPORATE PARK DR • LOUDON, TN 37774 USA • 800.527.6020 FAX 865.458.8575 • [astecunderground.com](http://astecunderground.com)

